



ST. FLANNAN'S COLLEGE
COLÁISTE FHLANNÁIN

First Year 2024/25

'Serving the diocese of Killaloe since 1846'

Mission Statement

- St. Flannan's College is a school community consisting of students, parents and staff, who are committed to working together to nurture the academic and personal growth of all the students towards mature and responsible adulthood.





ST. FLANNAN'S COLLEGE
COLÁISTE FHLANNÁIN

- ❖ St Flannan's takes its inspiration from the tradition and values of its founding Trustees and Staff.
- ❖ Student-centred focus
- ❖ Academic excellence
- ❖ Sporting excellence
- ❖ Breadth of Co-curricular and Extra Curricular opportunities

Getting to know one another



ST. FLANNAN'S COLLEGE
COLÁISTE FHLANNÁIN

- ❖ Primary school Induction Visits
- ❖ School visits
- ❖ Open Night
- ❖ CAT 4 Aptitude Tests
- ❖ Parent Teacher Meetings
- ❖ Subject Information Evenings – this evening

Student Care



ST. FLANNAN'S COLLEGE
COLÁISTE FHLANNÁIN

❖ Who may your son/daughter turn to ?

- ❖ Parent /Guardian
- ❖ Teacher
- ❖ Class Tutor
- ❖ Year Head
- ❖ TY Mentors/Buddies

- ❖ Guidance Counsellors
- ❖ Senior Management

Your Child – A time of Change



ST. FLANNAN'S COLLEGE
COLÁISTE FHLANNÁIN

- ❖ Transition – Takes time
- ❖ 6th class – 1st year
- ❖ Adolescence
- ❖ Home-School Partnership
- ❖ Learning more about themselves

Transition to Secondary School



ST. FLANNAN'S COLLEGE
COLÁISTE FHLANNÁIN

- Change in day-to-day routine
- Change from one teacher to several teachers; every 40 minutes
- Change of location from class to class
- Change in classmates
- “New – ness’ can cause worry: parents, try to be supportive and understanding, while encouraging resilience
- Ensure your child eats well and gets plenty of rest: no mobile in the bedroom!
- Organisation of school bag, uniform and locker
- Homework increase – time management: written hw, learning and revision
- Classroom Based Assessments (CBAs)
- Extra-Curricular activities

Code of Positive Behaviour

❖ Respect

❖ Self-Discipline

❖ Performance depends on engagement

❖ Intelligence is not fixed, it depends on student motivation and application to study

❖ Dress Code – Uniform (Available from McCannon's)

❖ Mobile Phone Policy

❖ Social Networking and Texting



ST. FLANNAN'S COLLEGE
COLÁISTE FHLANNÁIN

Use of Phones & Social Media

- ❖ Establish clear boundaries.
- ❖ Phone/device should **not** be in the bedroom with a young child.
- ❖ With young teens the majority of abusive or inappropriate texts/pictures are sent or received when the child is alone in their bedroom.
- ❖ Encourage your child to speak up and not to be a silent by stander.
- ❖ What is deemed acceptable or unacceptable behaviour when using social media and group chats.
- ❖ It is an offence to take a picture of another without their expressed permission and if they are a child, permission must be sought from their parent or guardian.
- ❖ We encourage parents & guardians to monitor all their child's access to social media and YouTube.

Home and School

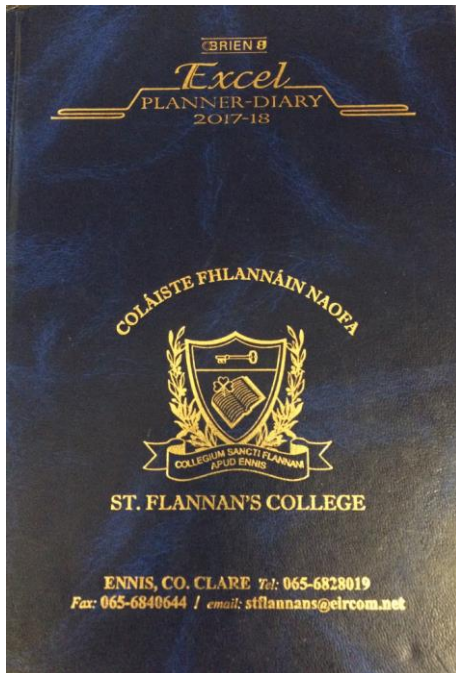

- ❖ Homework Journal
- ❖ Involvement
- ❖ Communication – a good link between school & home

Safety

- ❖ To and from school
- ❖ Behaviour on buses & waiting for buses
- ❖ Traffic congestion
- ❖ Lunch-time
- ❖ Hot Lunches
- ❖ Rainwear - Jacket



ST. FLANNAN'S COLLEGE
COLÁISTE FHLANNÁIN

Time Management



ST. FLANNAN'S COLLEGE
COLÁISTE FHLANNÁIN

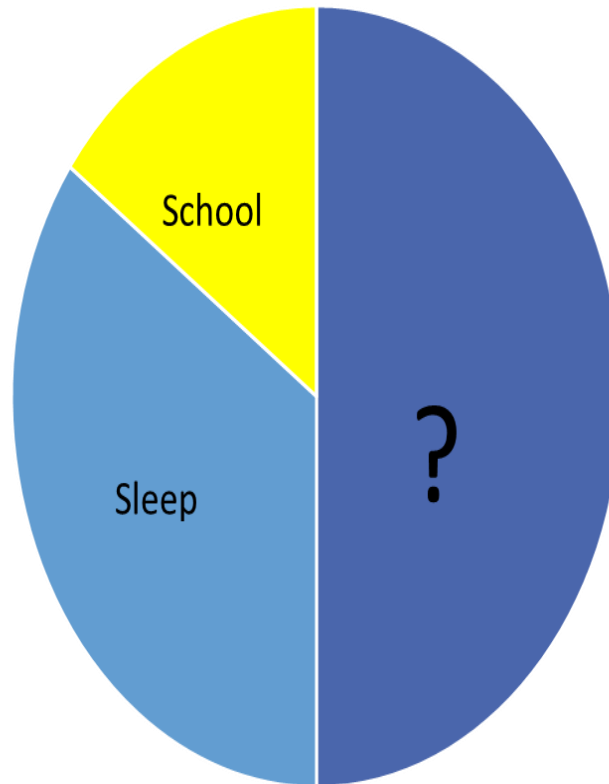

Second-level
Student

Only 1 hour in
every 8 at School

Facilities



Extra-Curricular Activities

Extra Curricular Activities

- ❖ Hurling
- ❖ Gaelic Football
- ❖ Camogie
- ❖ Ladies Football
- ❖ Volleyball
- ❖ Golf
- ❖ Coding lunchtime

- ❖ Athletics
- ❖ Tennis
- ❖ Swimming
- ❖ Basketball
- ❖ Trad Group
- ❖ Badminton
- ❖ Chess club lunchtime
- ❖ Rugby

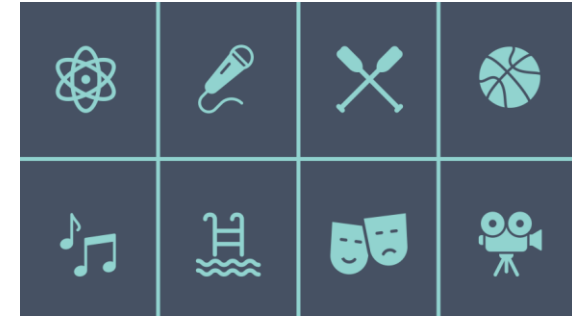



-08:19

Class Groups

All class groups will be made prior to the students starting school.

Our best attempt will be made to accommodate students in their desired chosen subject and if possible they will be placed in groups with some of their peers from their primary school so there will be some level of familiarity when they start.

Classes are:

- ❖ Typically between 24/30
- ❖ Mixed ability classes in 1st Year
- ❖ Boys and Girls in each class



Aptitude Tests

- On this Saturday students will complete some short aptitude tests
- 2 hours in duration
- There will be lots of breaks and everything will be explained for the children.
- No need to worry - no preparation needed.
- All stationary be will supplied, just bring a bottle of water.

Time of arrival

9.20 Drop & Go

There will be lot of traffic on the morning so as to aid with congestion please drop and go.

Collection 12.30pm.

Secondary School Programme

- ❖ 3 Year Programme leading to Junior Cycle, followed by a 2 year Programme leading to Leaving Cert
- ❖ Transition Year is a 1 year optional programme after the Junior Cycle
- ❖ In Junior Cycle, students get a broad grounding in a wide variety of subjects
- ❖ For Leaving Cert, students make choices about which subjects they wish to take



shutterstock.com · 1899513844

Subjects taken by all to Junior Cycle:

- ❖ Maths
- ❖ Irish (unless exempt)
- ❖ English
- ❖ Business Studies
- ❖ History
- ❖ Geography
- ❖ Science
- ❖ Religious Education
- ❖ Wellbeing:
 - ❖ - CSPE (Civic, Social and Political Education)
 - ❖ - SPHE (Social, Personal and Health Education)
 - ❖ - Physical Education
 - ❖ - Digital Wellbeing

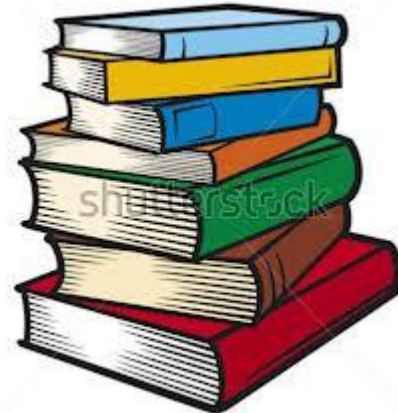

www.shutterstock.com - 02747322

& a European Language



French

or



German



& 1 Optional Subject



- Classical Studies
- Visual Art
- Materials Wood Technology
- Technical Graphics
- Home Economics
- Music

**CHOICE OF 6
STUDENTS ONLY
PICK 1**

We will try our best to ensure that every student gets their 1st or 2nd choice, but due to capacity and demand this is not always possible.

A link will be sent Saturday for you to make your subject choice

Level of Subjects for Junior Cycle

- Most subjects are common level for the Junior Cycle except for:
- English – stay in base class for 3 years
- Irish - classes are reviewed at the start of 2nd year
- Maths – classes are reviewed at the start of 2nd year

Technical Graphics

Speaker: Nathan

Some of the things that students will learn are:

- ❖ How to produce drawings using relevant equipment, freehand and using computers (SolidWorks)
- ❖ How to read and interpret drawings and diagrams
- ❖ Develop students' spatial and graphic skills
- ❖ Use a variety of media to produce sketches and use computer aided design to aid the process further
- ❖ Mathematically average or above an advantage
- ❖ Project worth 30%
- ❖ Assessed by exam at the end of 3rd year (worth 70%)





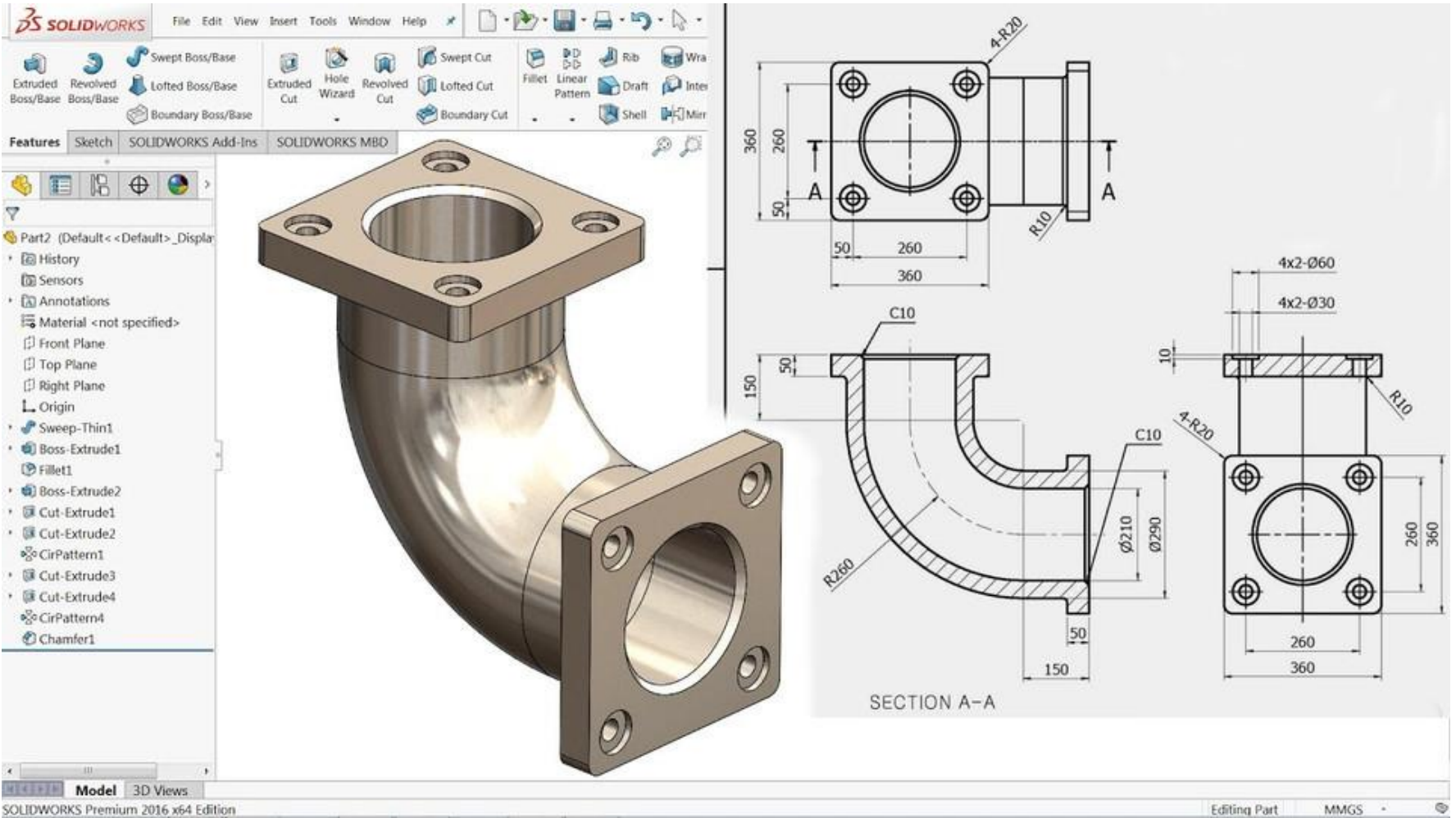

Junior Cycle CBA/Project

BRENDAN O'HALLORAN

Graphics Project - Kettle

Function

Kettle – used for boiling water for drinks, cooking food and for cleaning and sterilising surfaces.

Heating Element- electricity runs through the element, coiled in a circle, and heats up the water.

Aesthetics

Kettle has a glossy, polished look which is pleasing to the eye.

Spout – has built in filter to stop lime scale

Geometry

Cylindrical body

Curved handle for the most comfortable grip

Safety

Thermostat- switches kettle off once boiling point is reached, doesn't over-boil.

Base- kettle won't boil unless kettle is placed on base

Lid- lid closes with a lock, can only be opened while holding a button.

Borosilicate glass- doesn't crack or break while boiling.

Fuse- if an excessive current reaches the kettle, the fuse will blow, saving the kettle from damage.

Ergonomics

Thermostat- regulates the temperature, switches off when boiling point is reached.

Measure- tells you how much liquid is in the kettle.

Easy, pop-open lid.

Shapes

Base – cylinder, matches the base of kettle

Charging connector – cylinder, fits into hole in the base of kettle.

Lid – hemi-sphere, intruded slot for grip

Materials & Properties

Steel- durable, tensile strength, conductivity, rust resistant

Plastic- low-density, lightweight, impact resistant

Rubber- strong, tough, impermeable to water

Glass- tensile strength, compressive strength

Detachable Base- kettle can be lifted easily from base in order to pour water.

All these features provide maximum comfort and functionality when using a kettle.

Research

Primary

Researched the geometry and the ergonomics of my kettle at home.

Secondary

[Functionality and Materials - Kettle Heating Elements \(weebly.com\)](#)

[The Best Tea Kettle Options for the Kitchen in 2021 - Bob Vila](#)

Classical Studies

Speaker: Darragh



Classical Studies

Some of the things the students will learn are:

- ❖ Ancient Greek and Roman mythology
- ❖ Daily life in Ancient Greece and Rome
- ❖ Classical architecture and art
- ❖ Studies of Athens, Crete, Troy, Rome, Pompeii etc.
- ❖ Famous characters such as Socrates, Julius Caesar Cleopatra
- ❖ Warfare and conquest
- ❖ 2nd year CBA- create a myth
- ❖ 3rd year CBA- study a Roman structure





GREEK AND ROMAN GODS

22 vector characters



Art, Craft & Design

Speaker: Áine



Visual Art

Some of the things that students will learn are:

- ❖ Learn a variety of new crafts
- ❖ Learn to work in 3-D e.g. construction, sculpture or clay work
- ❖ Learn about the design process
- ❖ Classroom based assessment (CBA):
 - 1 project in 2nd year
 - 1 project in 3rd year
- ❖ No final exam, assessed through CBAs











Materials Wood Technology

Speaker: Oscar

Some of the things that students will learn are:

- ❖ How to use freehand sketching to communicate ideas
- ❖ How to prepare a design drawing/plan
- ❖ How to read design drawings and make small projects
- ❖ The safe use of tools
- ❖ Project in 3rd Year (worth 70%)
- ❖ Strictly 24 per class (typically 3 class groups)







Samples of Junior Cert projects





Home Economics

Assessment for the Junior Cert consists of

- ❖ Two Classroom-Based Assessments (CBA)
- ❖ Creative Textiles and a Food Literacy Skills Brief
- ❖ A practical food skills examination (50% Junior Cycle exam)
- ❖ A written examination.

All assessments will be at a common level







Music

Speaker: Jack



Some of the things that students will learn are:



- ❖ Focus on 3 key areas: Composition, Performing and Listening
- ❖ How to read and write music
- ❖ Use new technology (recording equipment, making videos, recording compositions)
- ❖ Different genres of music- classical, folk, jazz etc.
- ❖ **30% of exam in 3rd year consists of a practical exam**
- ❖ **NOTE:** The College does not provide or rent instruments



Strong interest in music desirable, prior experience playing an instrument would be an advantage





Reminder:

A link will be sent to you on Saturday for your child to make their subject choice. Please complete by Tuesday.

You will be asked to:

(1) Choose French or German

(2) List your top 3 optional subjects in order of preference



Rainbows Ireland

Supporting Children and Young People with
Bereavement and Parental Separation

TÚSLA
An Ghníomhaireacht um
Leanaí agus an Teaghlach
Child and Family Agency

WHAT WORKS
SHARING KNOWLEDGE
Improving Children's Futures

ciste na
gcuntas díomhaoin
the dormant
accounts fund

Rainbows.. In brief...



Bereavement

Separation/
Divorce

- Rainbows is a peer support group for our students who have suffered a loss of one type or another.
- 9 week, after school programme
- Small groups (4 - 8 students)
- Similar age
- Similar loss type
- Free service



Thank you for attending our
information evening.

Further Information



❖ www.stflannanscollege.ie

❖ @stflannans

❖  St Flannan's College Official

