



Incoming First Years 2026 - 2027

St. Flannan's College

Mission Statement

St. Flannan's College is a school community consisting of students, parents and staff, who are committed to working together to nurture the academic spiritual and personal growth of all the students towards mature and responsible adulthood.



Getting to know one another

- ❖ Open Day
- ❖ Primary school Induction Visits
- ❖ Subject Information Evenings
- ❖ Aptitude Tests
- ❖ Parent Teacher Meetings
- ❖ Informal Meetings



Student Care

who can your son/daughter turn to?

- ❖ Parent /Guardian
- ❖ Class Tutor
- ❖ Year Head
- ❖ Guidance counsellors
- ❖ Senior Management
- ❖ TY Mentors/Buddies



Unlike primary school, secondary schools have Guidance Counsellors. All students are entitled to talk to one if they wish, on any matter, be it personal or educational.

Your Child – A time of change

The transition from primary to secondary school is a big change but manageable with some forward planning; bear in mind the following for a smoother transition for everyone:

- ❖ Constant change throughout the day – which will eventually become routine
- ❖ Increased number of subjects and teachers
- ❖ The schoolbag and locker
- ❖ Homework/Projects/CBAs – how to manage this effectively
- ❖ Regular school reports
- ❖ Extra-curricular activities
- ❖ SST – Student Support Team Meetings occur weekly for each Year Group. Support network in school – Year Head, Guidance Counsellors, Deputy Principal, AEN Coordinator – support is here if and when you need it.



Code of Positive Behaviour

- ❖ Respect
- ❖ Honesty
- ❖ Bí Cineálta – Anti Bullying Policy
- ❖ Performance depends on many factors
 - ❖ Intelligence is not fixed, it depends on student motivation, revision/study, engagement
- ❖ Dress Code – Uniform (Available from Mannix & Pynes)
- ❖ Mobile Phone Policy – Phone Pouches
- ❖ Social Networking and Texting

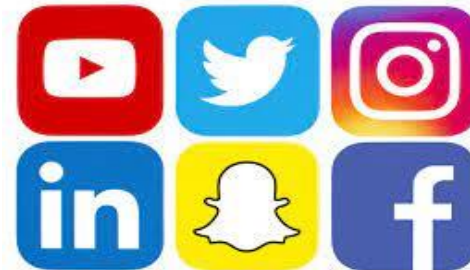





Wriggle Student Device Parent Presentation **St. Flannan's College**
Date **26th March 2026**



Unit G6, Calmount Business Park
Ballymount, Dublin 12, Ireland
info@wrigglelearning.ie
+353 01 500 9060

Private & Confidential

What does the service include for parents?



SUPPORTED THROUGHOUT ENTIRE TIME IN SCHOOL

Technical support via phone and email for parents and students.



DEVICE CONFIGURATION

Bespoke setup and management for each student.



TRAINING

Complimentary access to 1000's of training videos on Wriggle Connect Family.



DEVICE SECURITY

Secure device configuration using MDM to ensure device is for educational use only.



REPAIRS & LOANERS

Management of warranty repairs alongside logistics support. Also, the provision of a device loaner programme for quick swap-out.



INTEREST FREE PAYMENT PLANS

Pay off your bundle with 12 interest free payments

Private & Confidential

Important Contacts

Parent Support

The Parent Support channel is used for issues and queries relating to store orders, hardware & software issues, device repairs, sales and more.



01-5009060



info@wrigglelearning.ie

ASUS BR12 Bundle Cost Breakdown (1st Years)

ITEM	DETAILS	PRICE (inc.VAT)
ASUS BR12 12.2" Windows 2-in-1	<ul style="list-style-type: none"> • Processor: Intel® N150 • RAM: 8GB • Storage: 128GB • Operating System: Windows 11 Pro • Warranty: 3-year Extended Warranty • Accidental Damage Cover included • Display: 12.2", touch screen with Gorilla® Glass • Battery: 50Wh, up to 10 hours • Connectivity: Wi-Fi 6 and Bluetooth 5.2 • Ports: USB-C (display/power), USB 2.0 Type-C, 2x USB 3.2 Type-A, HDMI 1.4, Ethernet, headphone jack • Durability: MIL-STD 810H military-grade certified • Weight: 1.47 kg (with battery) 	€559
Case	<ul style="list-style-type: none"> • Heavy Duty Protective Case 	€40
Senso Internet Content Filtering & Classroom Management	<ul style="list-style-type: none"> • Senso Class Cloud (Classroom Management) • Senso Content Filter (Internet Filter) • 6yr License 	€35
Configuration, Service & Support**	<ul style="list-style-type: none"> • Wriggle bespoke online store • Device Configuration • Liaise with publishers for single sign-on • Home Delivery • Wriggle Connect Family License • Support entire time in school • SwapIT • Access to Wriggle Pay 0% interest 	€120
Total with Delivery		€761.99

What is accidental damage cover?

Device



- Covers unexpected physical damage (not manufacturer faults)
- Includes cracked screens, liquid spills, broken ports, damaged keyboards
- Specifically for user-caused accidents (e.g. drops, bumps, misuse)
- Handled in-house by Wriggle
- Devices shipped with prepaid label; loan device provided.
- Not to be confused with insurance – no excess, faster service



Important Dates

- **Today:** Parent store opens
- **21st June:** Store closes
- **Mid-August:** Back-to-school Webinars
- **Late August:** Wriggle School Deployment Day

Late Fees apply if date is missed

Home and School

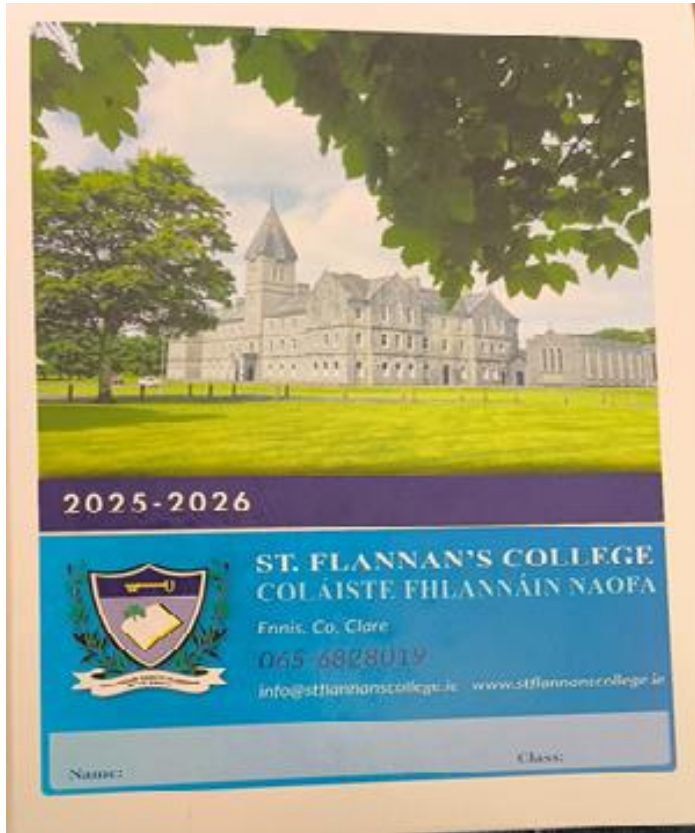

- ❖ School App – Contact with Year Head – Log Absence – Weekly information and announcements to parents
- ❖ Homework Journal
- ❖ Involvement
- ❖ Communication

Safety at school

- ❖ To and from school
- ❖ Behaviour on buses
- ❖ Traffic congestion
- ❖ Lunch-time
- ❖ Hot Lunches

1st year students are not permitted to leave school grounds during break or lunch. Bring packed lunch or lunch can be purchased from the school canteen – Cash or card can be used – no phone payment

Extra Curricular Activities

- ❖ Camogie
- ❖ Ladies Football
- ❖ Hurling
- ❖ Gaelic Football
- ❖ Coding Club
- ❖ Badminton
- ❖ Golf

- ❖ Athletics
- ❖ Tennis
- ❖ Swimming
- ❖ Basketball
- ❖ Trad Group
- ❖ Chess Club

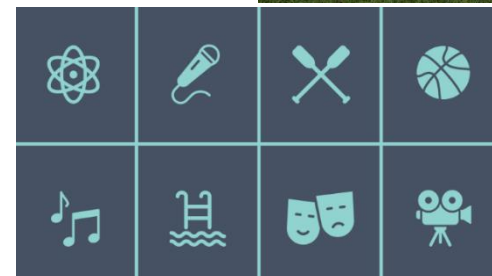

Class Groups

Ms McMenamin

All class groups will be made prior to the students starting school. Our best attempt will be made to accommodate students in their desired chosen subject and where possible they will be placed in groups with some of their peers from their primary school so there will be some level of familiarity when they start.

Classes are:

- ❖ Typically up to 30 in a class
- ❖ Mixed ability classes in 1st Year
- ❖ Boys and Girls in each class



Aptitude Tests

On Saturday April 18th students will complete some short aptitude tests, these will take 2 hours to complete, there will be lots of breaks and everything will be explained for the students.

They are nothing to worry about, no preparation needed.

All stationery be will supplied, just bring a bottle of water.

Time of arrival

Surnames

Time

A – L

9.20 – drop and go

M – Z

9.35 – drop and go

There will be lot of traffic on the morning so as to aid with congestion please drop and go. TY students will be outside to assist children being dropped off. Collection 12.45pm approx.

Secondary School Programme

- ❖ Three Year Programme leading to Junior Cycle, followed by a two-year Programme leading to Leaving Cert
- ❖ In between Junior Cycle & Senior Cycle we offer Transition Year
- ❖ In Junior Cycle, students get a broad grounding in a wide variety of subjects
- ❖ For Leaving Cert, students make choices about which subjects they wish to take



Subjects taken by all to Junior Cert.

- ❖ Maths
- ❖ Irish (unless exempt)
- ❖ English
- ❖ Business Studies
- ❖ History
- ❖ Geography
- ❖ Science
- ❖ Religious Education
- ❖ CSPE (Civic, Social and Political Education)
- ❖ SPHE (Social, Personal and Health Education)
- ❖ Physical Education
- ❖ Digital Wellbeing

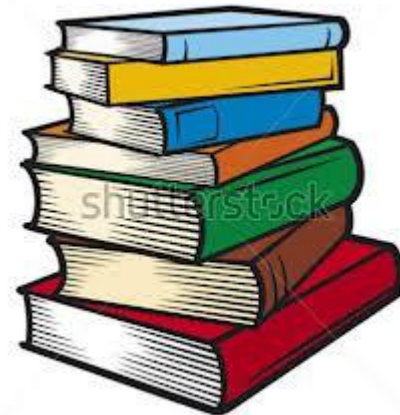

www.shutterstock.com - 02747322

European Language



French

or



German

Students pick 1

Optional Subjects

Classical Studies

Visual Art

Wood Technology

Graphics

Home Economics

Music

**CHOICE OF 6
STUDENTS PICK 1**

We will try our best to ensure that every student gets their 1st or 2nd choice, but due to capacity and demand this is not always possible.

A link will be sent on the school app on Monday 13th April for you to make your subject choice.

Classical Studies

Some of the things the students will learn are:

- ❖ Ancient Greek and Roman mythology
- ❖ Daily life in Ancient Greece and Rome
- ❖ Classical architecture and art
- ❖ Studies of Athens, Crete, Troy, Rome, Pompeii etc.
- ❖ Famous characters such as Socrates, Julius Caesar Cleopatra
- ❖ Warfare and conquest
- ❖ 2nd year CBA- create a myth
- ❖ 3rd year CBA- study a Roman structure



Visual Art

Some of the things that students will learn are:

- ❖ Learn a variety of new crafts
- ❖ Learn to work in 3-D e.g. construction, sculpture or clay work
- ❖ Learn about the design process
- ❖ Classroom based assessment (CBA):
 - 1 project in 2nd year
 - 1 project in 3rd year
- ❖ No final exam, assessed through CBAs





Wood Technology

Some of the things that students will learn are:

- ❖ How to use freehand sketching to communicate ideas
- ❖ How to prepare a design drawing/plan
- ❖ How to read design drawings and make small projects
- ❖ The safe use of tools
- ❖ Project in 3rd Year (worth 66%)
- ❖ Strictly 24 per class (typically 3 class groups)



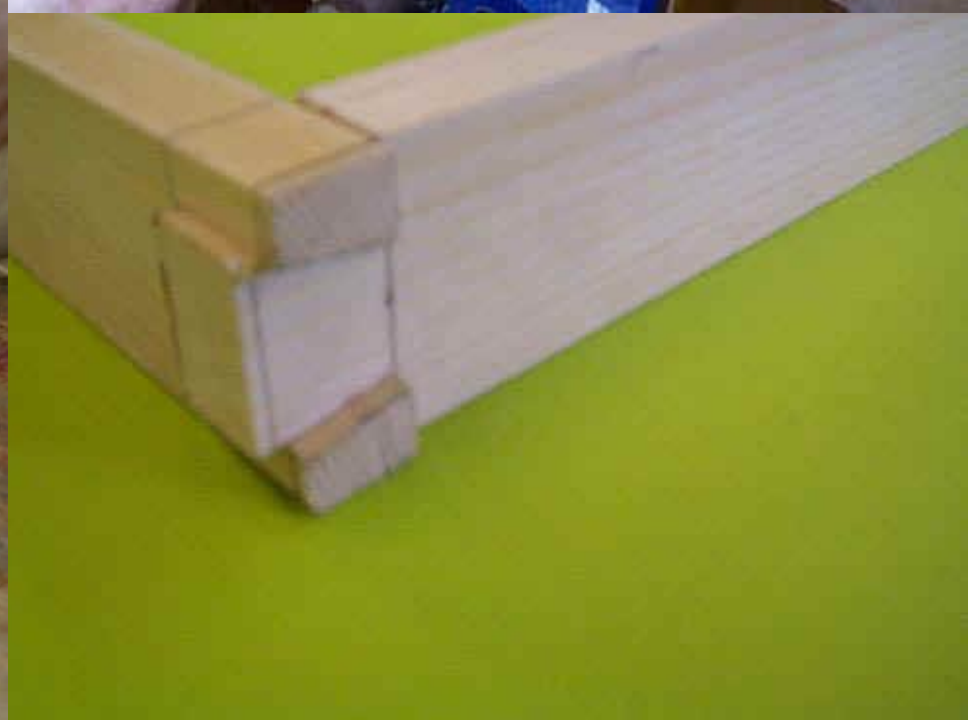
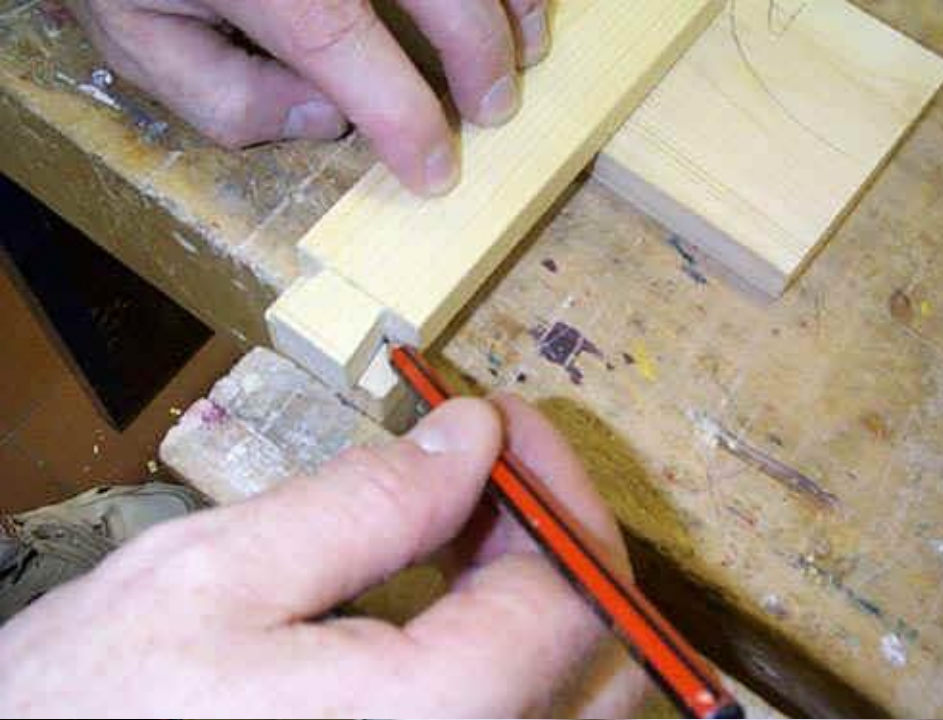

Graphics



Some of the things that students will learn are:

- ❖ How to produce drawings using relevant equipment, freehand and using computers (SolidWorks)
- ❖ How to read and interpret drawings and diagrams
- ❖ Develop students' spatial and graphic skills
- ❖ Use a variety of media to produce sketches and use computer aided design to aid the process further
- ❖ Mathematically average or above an advantage
- ❖ Assessed by exam at the end of 3rd year

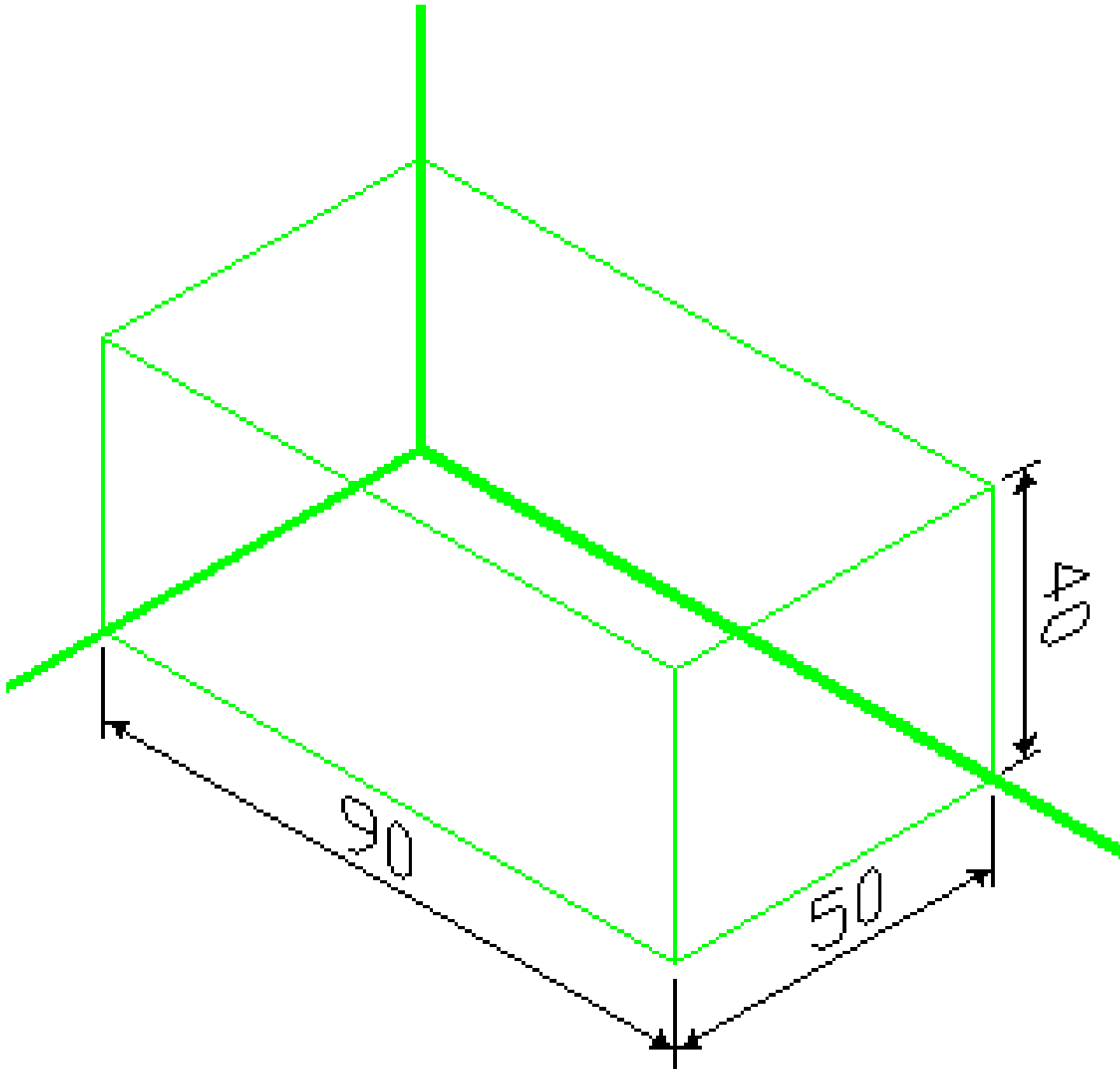

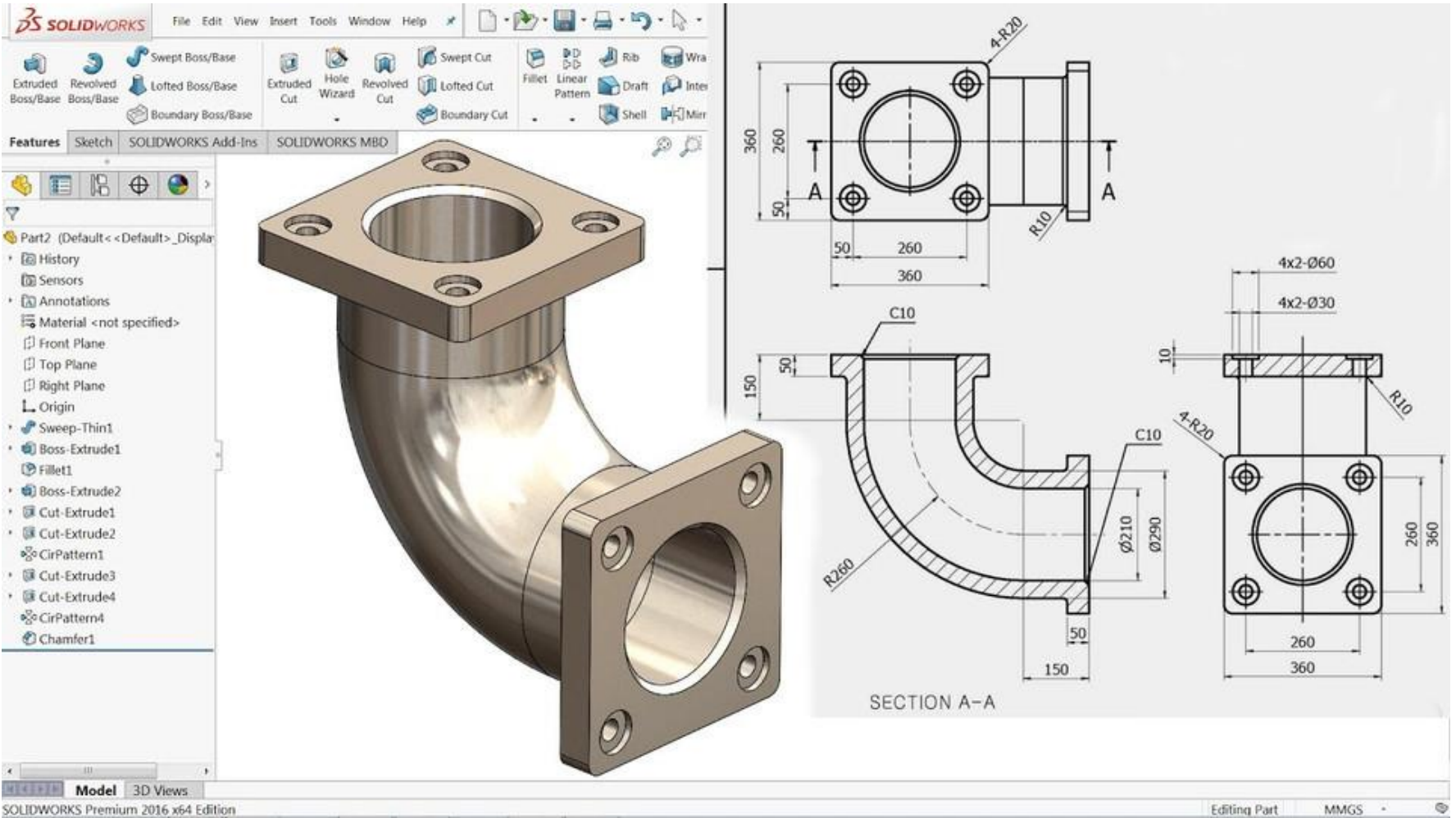

Home Economics

Assessment for the Junior Cert consists of

- ❖ Two Classroom-Based Assessments (CBA)
- ❖ Creative Textiles and a Food Literacy Skills Brief
- ❖ A practical food skills examination
- ❖ A written examination.
- ❖ Cookery Skills exam worth 50% in 3rd year

All assessments will be
at a common level





Music



Some of the things that students will learn are:



- ❖ Focus on 3 key areas: Composition, Performing and Listening
- ❖ How to read and write music
- ❖ Use new technology (recording equipment, making videos, recording compositions)
- ❖ Different genres of music- classical, folk, jazz etc.
- ❖ 30% of exam in 3rd year consists of a practical exam
- ❖ **NOTE:** The College does not provide or rent instruments
Strong interest in music desirable, prior experience playing an instrument would be an advantage







Interest is the most important thing...

As with anything your son or daughter will get the most out of the subject if they are interested and have a desire to do the subject

Take a look at the links to read about each subject

<https://www.curriculumonline.ie/Junior-cycle/Junior-Cycle-Subjects/>

<https://www.studyclix.ie/subjects>

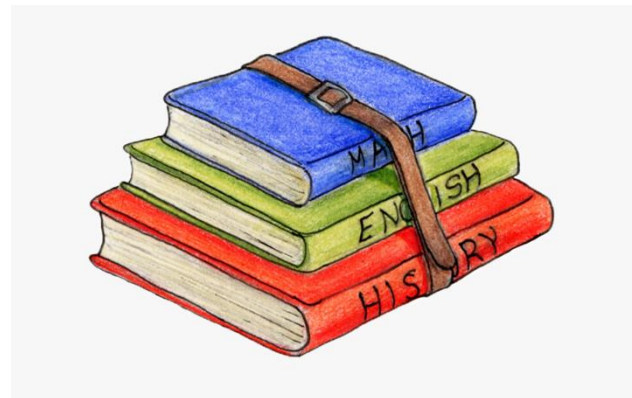

Guidance and Counselling Department

- Administers aptitude tests
- Personal Counselling
- Educational Counselling
- Vocational Counselling



How students can access the Guidance Counsellor:

- Seek us out on their own
- Referred by the Student Support Team – weekly meetings
- A teacher may notice a change in a student and refer to Year Head
- Another student may have a concern
- By a parent/guardian

Additional Educational Needs

- We provide support in line with the Dept. of Education Guidelines; those with the most need get the most support.
- Information from primary schools, CAT 4 tests, PPAD-E and parents/guardians.
- Students with Irish exemptions from Primary School will attend AEN support/classes opposite Irish.
- Additional support may be provided opposite French/German on a needs basis.
- There is open communication with home on a continual basis through our AEN co-ordinator Ann Marie McGann, Deputy Principal Grainne Lynch and Deirdre Savage for our ASD class placements as required.

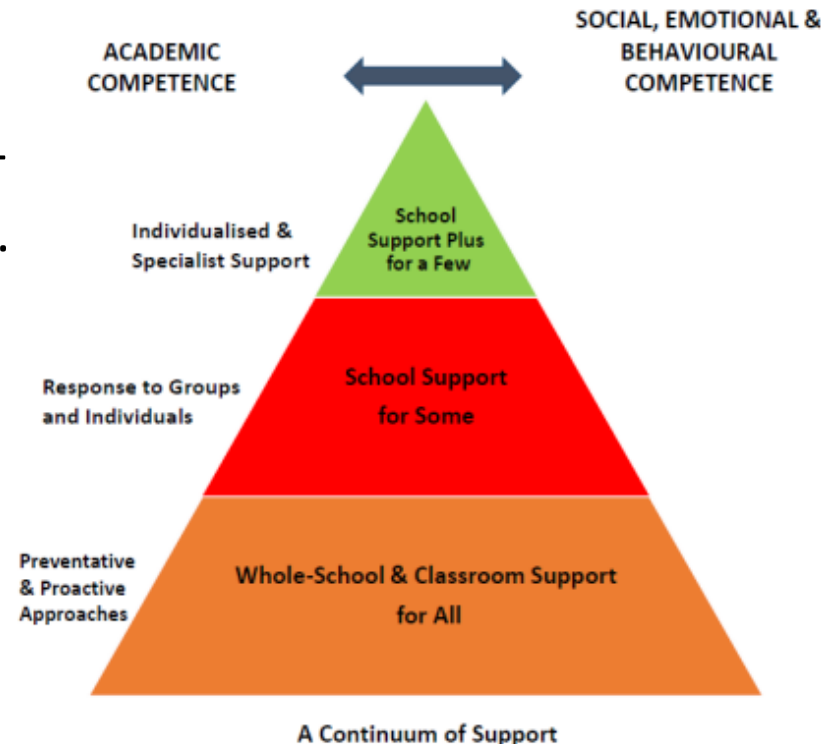



Supporting Children and Young People with
Bereavement and Parental Separation

Bereavement

Separation/
Divorce

- Rainbows is a peer support group for our students who have suffered a loss of one type or another
- 8 week in school programme
- Small groups (4 - 8 students)
- Similar age
- Similar loss type
- Free service

Thank you for your attention
and we look forward to
welcoming you to our school

We will send all this
information to you on the
school app